

500 mW DO-35 Hermetically Sealed Glass Fast Switching Diodes



AXIAL LEAD
DO35

Absolute Maximum Ratings $T_A = 25^\circ\text{C}$ unless otherwise noted

Symbol	Parameter	Value	Units
P_D	Power Dissipation	500	mW
T_{STG}	Storage Temperature Range	-65 to +200	$^\circ\text{C}$
T_J	Operating Junction Temperature	+175	$^\circ\text{C}$
W_{IV}	Working Inverse Voltage	75	V
I_O	Average Rectified Current	150	mA
I_{FM}	Non-repetitive Peak Forward Current	450	mA
I_{FSURGE}	Peak Forward Surge Current	2	A

These ratings are limiting values above which the serviceability of the diode may be impaired.

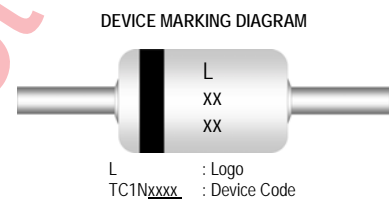

DEVICE MARKING DIAGRAM

L : Logo
TC1Nxxxx : Device Code

Specification Features:

- Fast Switching Device ($T_{RR} < 4.0$ nS)
- DO-35 Package (JEDEC)
- Through-Hole Device Type Mounting
- Hermetically Sealed Glass
- Compression Bonded Construction
- All external surfaces are corrosion resistant and leads are readily solderable
- Cathode indicated by polarity band

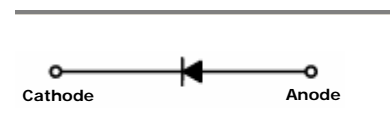

ELECTRICAL SYMBOL

Electrical Characteristics $T_A = 25^\circ\text{C}$ unless otherwise noted

Symbol	Parameter	Test Condition	Limits		Unit
			Min	Max	
B_V	Breakdown Voltage	$I_R = 100\mu\text{A}$	100		Volts
		$I_R = 5\mu\text{A}$	75		
I_R	Reverse Leakage Current	$V_R = 20\text{V}$		25	nA
		$V_R = 75\text{V}$		5	μA
V_F	Forward Voltage	TC1N4448, TC1N914B $I_F = 5\text{mA}$	0.62	0.72	Volts
		TC1N4148 $I_F = 10\text{mA}$		1.0	
		TC1N4448, TC1N914B $I_F = 100\text{mA}$		1.0	
T_{RR}	Reverse Recovery Time	$I_F = 10\text{mA}$, $V_R = 6\text{V}$ $R_L = 100\Omega$ $I_{RR} = 1\text{mA}$		4	nS
C	Capacitance	$V_R = 0\text{V}$, $f = 1\text{MHz}$		4	pF

Electrical Symbol Definition

Symbol	Parameter
B_V	Breakdown Voltage @ I_R
I_R	Reverse Leakage Current @ V_R
V_R	Reverse Voltage
I_F	Forward Current
V_F	Forward Voltage @ I_F

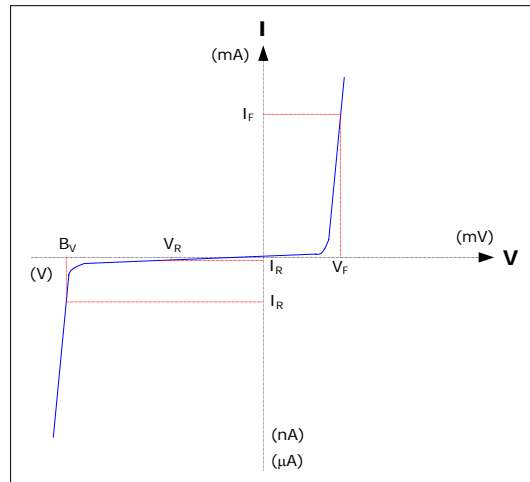
Typical Characteristics

Ordering Information

Device	Package	Quantity
TC1Nxxxx	Bulk	10,000
TC1Nxxxx.TB	Tape and Ammo	5,000
TC1Nxxxx.TR	Tape and Reel	10,000
TC1Nxxxx	Others (...contact Tak Cheong sales representatives)	

Axial-Lead Tape Packaging Standards

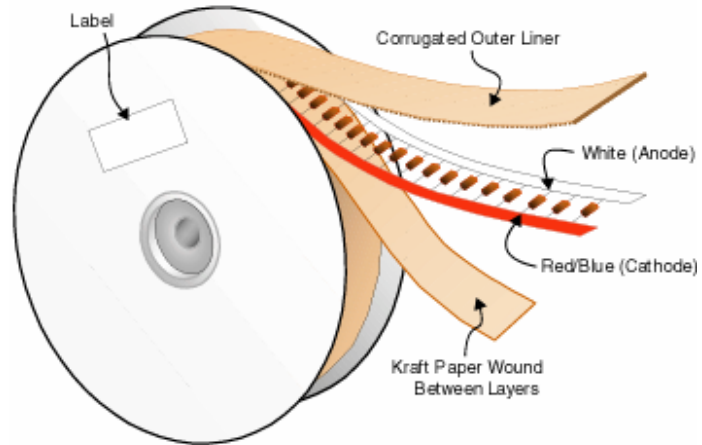
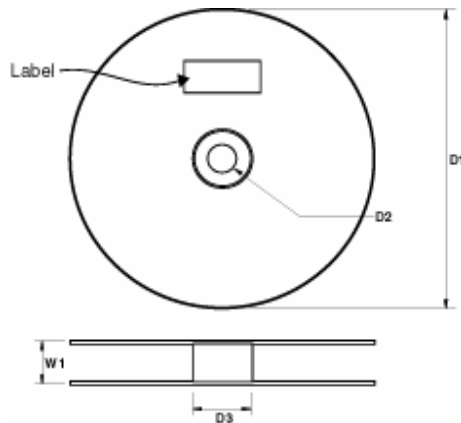
This axial-lead component's packaging requirements use in automatic testing and assembly equipment. And this standard practices for lead-tape packaging of axial-lead components meets the requirements of EIA Standard RS-296-D "Lead-taping of Components on Axial Lead Configuration for Automatic Insertion".

Tape & Reel Packaging Information
Tape & Reel Outline

Reel Dimensions

DIM	Millimeters
D1	356
D2	30
D3	84
W1	77.5

Quantity Per Reel

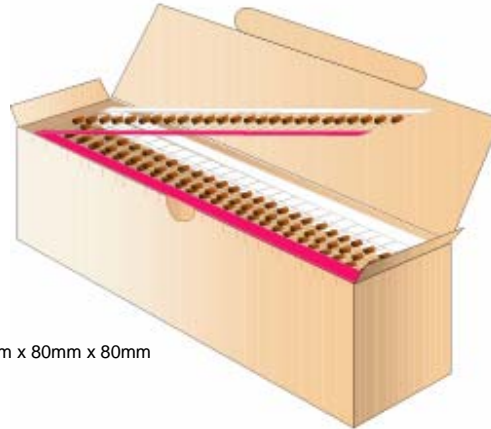
PKG Type	Quantity Per Reel
DO-35	10,000

Tape & Ammo Packaging Information
Tape & Ammo Outline

250mm x 80mm x 80mm

Quantity Per Ammo Box

PKG Type	Quantity Per Box
DO-35	5,000

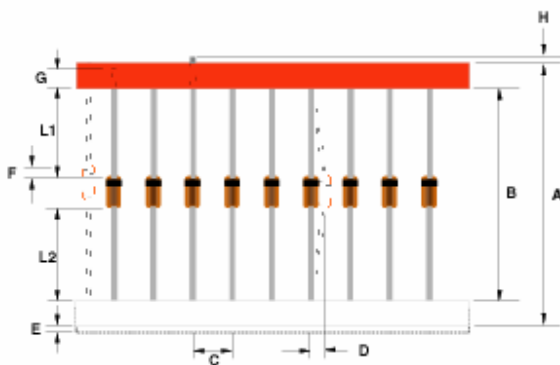
Taping Dimensions

Description	Millimeters	
	Standard Width	52
Tape Spacing (B)	52 ± 0.69	26 +0.5 / -0
Component Pitch (C)	5.08 ± 0.4	5.08 ± 0.4
Untaped Lead (L1 – L2)	± 0.69	± 0.69
Glass Offset (F)	± 0.69	± 0.69
Bent (D)	1.2 Max	1.2 Max
Tape Width (G)	6.138 ± 0.576	6.138 ± 0.576
Tape Mismatch (E)	0.55 Max	0.55 Max
Taped Lead (G)	3.2 Min	3.2 Min
Lead Beyond Tape (H)	0	0

Bulk Packaging Information

Bulk Outline

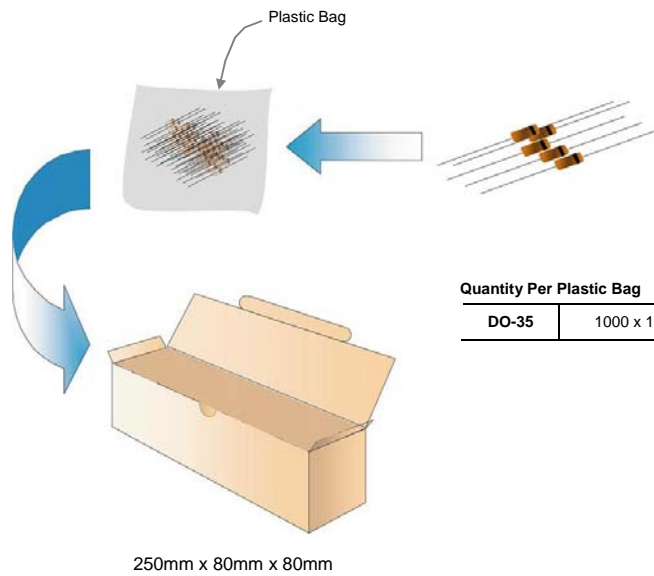

Quantity Per Box

PKG Type	Quantity Per Box
DO-35	10,000

Package Outline

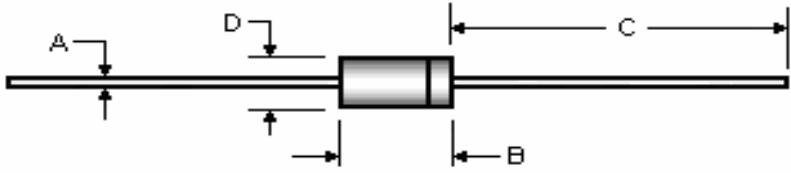
Package	Case Outline				
DO-35					
	DO-35				
	DIM	Millimeters		Inches	
		Min	Max	Min	Max
	A	0.46	0.55	0.018	0.022
	B	3.05	5.08	0.120	0.200
C	25.40	38.10	1.000	1.500	
D	1.53	2.28	0.060	0.090	

Notes:

1. All dimensions are within JEDEC standard.
2. DO35 polarity denoted by cathode band.