

REV	REASON	DIPLOMATE* DL (DUAL LEAF) DIP SOCKET	ENGINEERING RELEASE DATE 4-7-89
			APPROVAL RITA WHITNEY

1. INTRODUCTION

This specification covers the requirements for application of the AMP* DIPLOMATE DL (Dual Leaf) DIP sockets for manual and automatic application of the socket to a printed circuit (pc) board.

NOTE All dimensions in this specification are given in inches unless otherwise specified. Metric equivalents (mm) can be obtained by multiplying by 25.4.

Figure 1 shows an AMP DIPLOMATE DL DIP socket and its product features. The terms identifying the features are used throughout this specification.

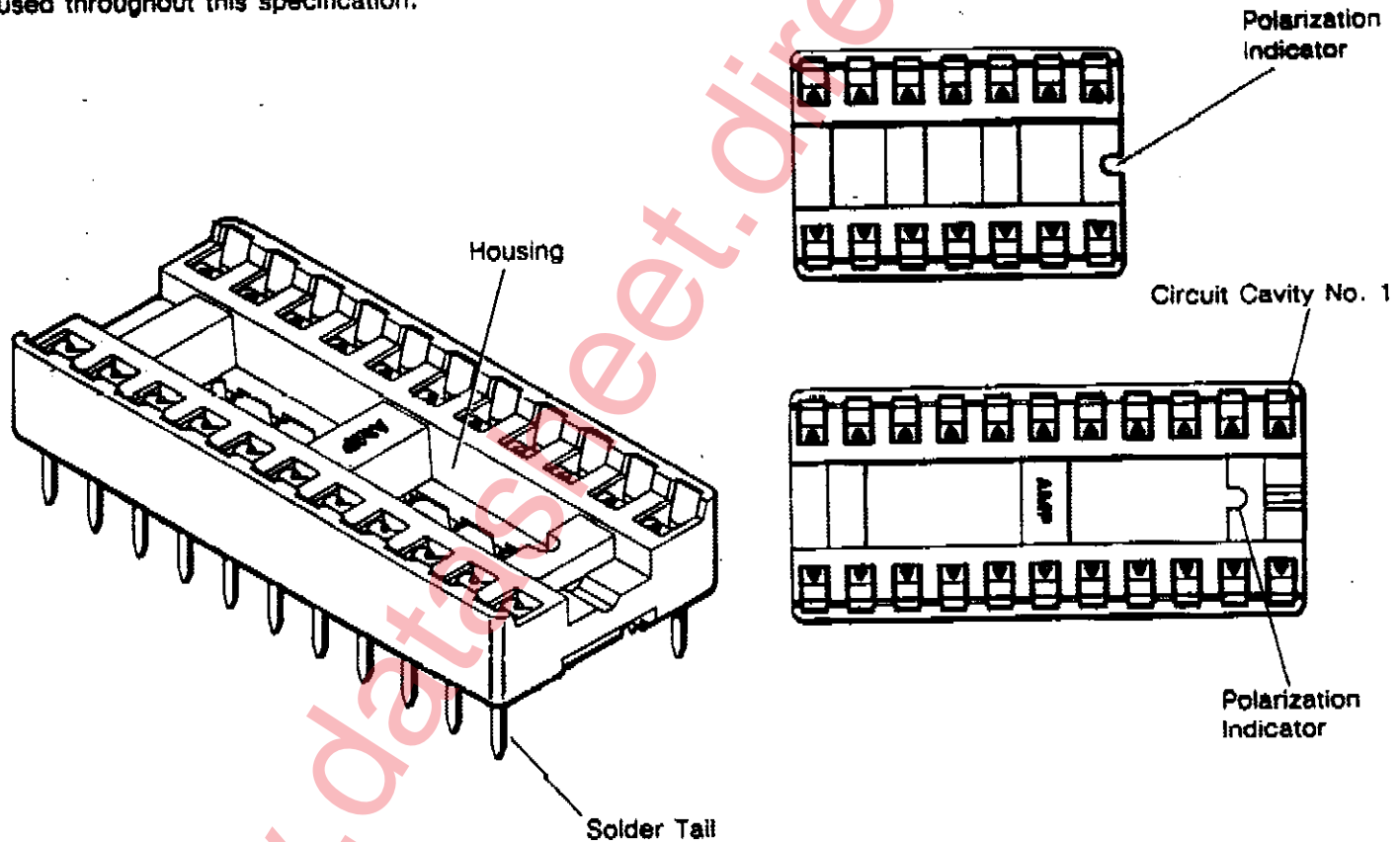

Fig. 1. Product Features

2. REFERENCE DOCUMENTS

2.1. Product Specification

AMP Product Specification 108-1066 covers product performance requirements for this product.

2.2. Customer Drawing

An AMP Customer Drawing is available for each part number assigned to this product line. In the event of a conflict between this specification and the customer drawing information, the customer drawing information will take precedence.

2.3. Product Numbers and Product Code

Product Part Number 641603 and Product Code 1529 are representative of the AMP DIPLOMATE DL DIP socket. Use of these numbers will identify the product line and expedite your inquiries through an AMP service network established to help you obtain product and tooling information. Such information can be obtained through a local AMP Representative (Field Sales Engineer, Field Applications Engineer, etc) or, after purchase, by calling the CUSTOMER HOTLINE at the top of the first page.

3. REQUIREMENTS

3.1. PC Board Layout Requirements

Printed circuit board layout requirements shall be as specified in Figure 2.

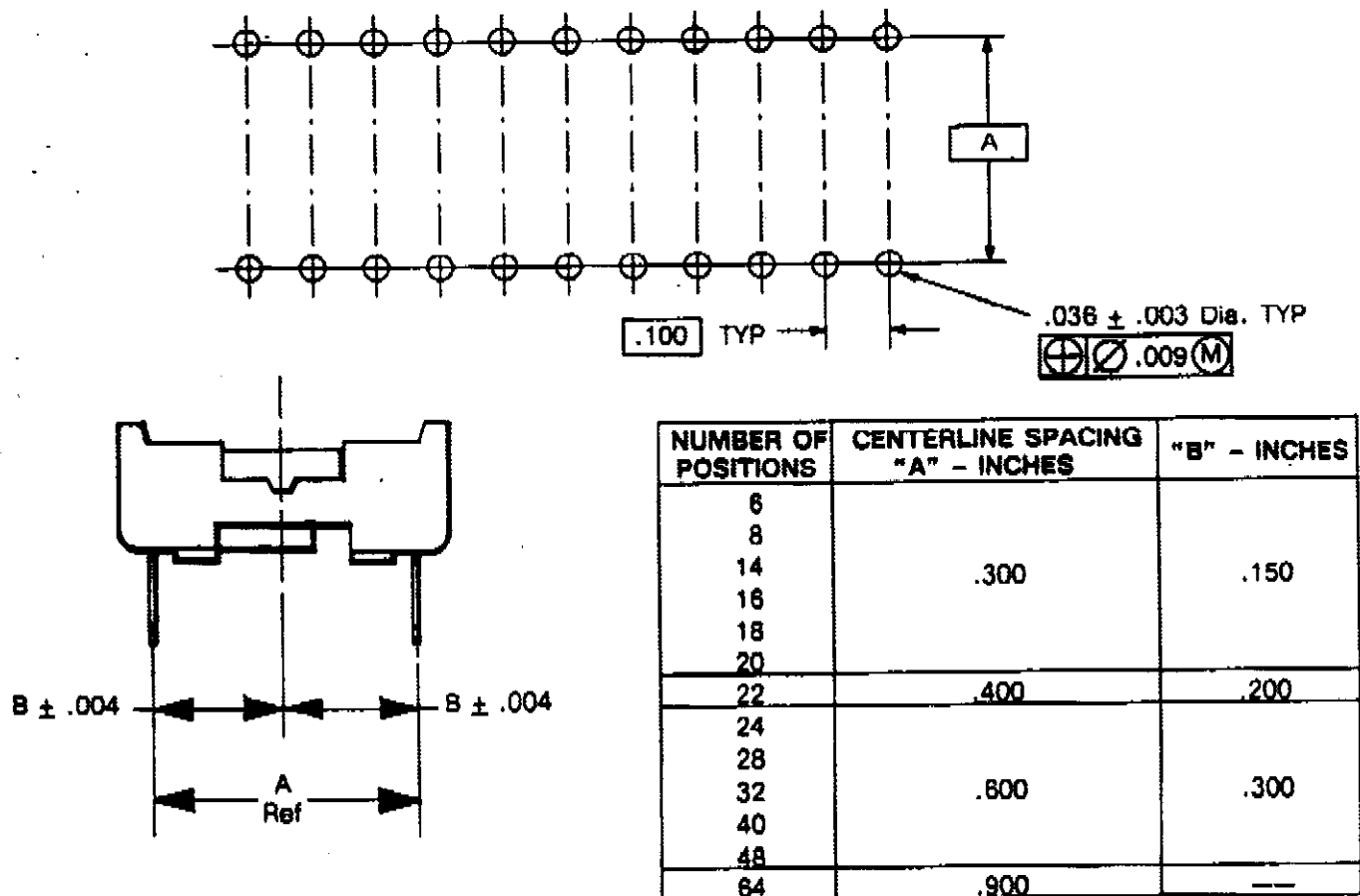

Fig. 2. PC Board Layout Pattern

3.2. PC Board Thickness

The maximum recommended pc board thickness is .093 inches.

3.3. Mounting Requirements

Insert solder tails into through holes of pc board, making sure the socket is parallel to and resting on the board. To hold the socket in place during handling and soldering, solder tail clinching may be desired. The method of clinching is at the discretion of the customer. Avoid applying excessive force to the ends of the solder tails (perpendicular to the board). This may dislodge the contact from its proper position in the housing.

NOTE

Sockets with the retention leg feature do not need clinching to hold them in place.

3.4. Soldering and Cleaning

A. Flux Selection

Prior to soldering, the solder tails shall be fluxed with a mildly activated rosin base flux. Proper flux selection will depend on the type of pc board used, and any components mounted on the board. Flux must also be compatible with the customer's flow solder line, as well as with manufacturing and safety requirements.

B. Soldering Guidelines

AMP Corporate Bulletin 52 is available upon request and can be used as a guide in soldering. This bulletin provides information on various flux types and characteristics along with the commercial designation and flux removal procedures. A checklist is attached to the bulletin which is intended to serve as a guide for obtaining information on soldering problems.

C. Cleaning

Removal of fluxes, residues, and activators is mandatory. Cleaning procedures are chosen by the customer and depend on the type of flux used on the solder line.

D. Drying

When drying cleaned assemblies and pc boards, make certain that a temperature of 105°C (85°C for copper alloy contact material) is not exceeded. Excessive temperatures may cause housing degradation and/or plating deterioration.

4. QUALIFYING SUPPORT

AMP DIPLOMATE DL DIP sockets are UL recognized and CSA certified.

5. TOOLING

The AMP DIPLOMATE DL Dip Sockets can be installed manually or by machine. AMP Tool and Product Engineers can help you design equipment and/or make recommendations for your particular set-up and application requirements. For assistance, consult your local AMP Representative or call the AMP Customer Hotline at the top of page 1.

6. VISUAL AID

Figure 3 shows a typically applied AMP DIPLOMATE DL DIP socket. The illustration depicts, in general, the conditions that production personnel should check to ensure a properly soldered product. Applications which are not visually correct should be dimensionally inspected using the information given in the main body of this specification.

HOUSING BOTTOMED ON PC BOARD

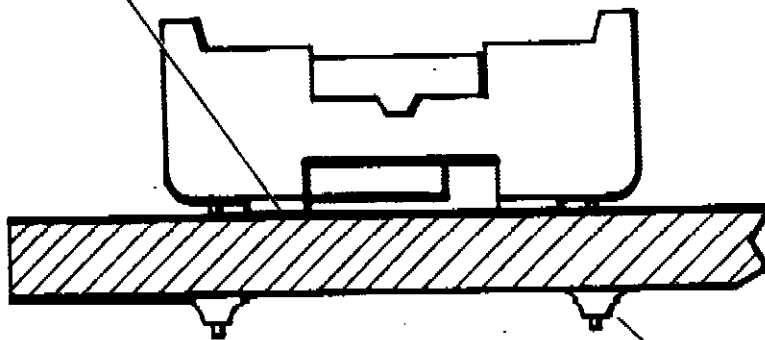

NO CRACKS IN SOLDER

FIG. 3. VISUAL AID